

## B12 VI-B-IVZO

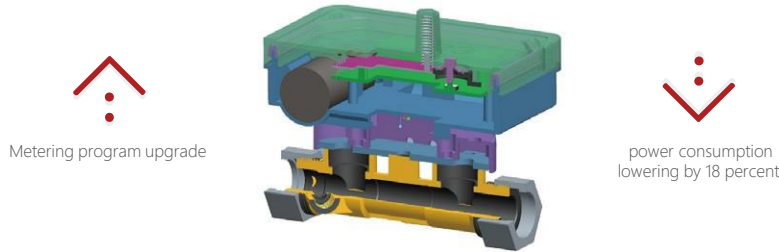

A next-generation ultrasonic heat meter, B12 VI-B-IVZO, is released after Bove engineers' long term dedication. A fresh new firmware enabling better flow sensor and longer battery plan for either wireless communication or wired communication.



**'No trouble, no fear'**

We build highly coordinated metering solution for our esteemed customers. At years after re-calibration, new B12 VI-B-IVZO and BOVE's B28 VTB series calibration and testing bench working consistently to make B12 VI-B-IVZO renew like original.

**DESCRIPTION**

B12 VI-B-IVZO Ultrasonic Heat Meter is an innovative heat meter with static flow sensor based on the ultrasonic measuring principle. B12 VI-B-IVZO is designed for measuring the use of heating in which water is the heat/ cool bearing medium.

It utilizes ultrasonic measuring methodology and microprocessor technology. All calculation and flow measuring circuits are designed on one single board, thus offering exceptional accuracy and reliability. B12 VI-B-IVZO gives importance to flexibility with its programmable functions and install-uninstall communication units.

With its size options from DN15 to DN40, it enables flow rate metering from 0.012 m<sup>3</sup>/h to 20 m<sup>3</sup>/h.



**KEY FEATURES**

- Advanced function
- Low pressure drops
- No metering of air
- Leading to long lasting metrology
- Wide dynamic metering range
- Pinpoint measuring accuracy
- Pre-equipped for communication
- Mounting in any installation position
- Insensitive against lime & sand
- Long product life, because there is no moving parts
- Automatic self diagnosis and fault detection

**IoT Ready.**

B12 VI-B-IVZO supports multiple communication interfaces for both wired and wireless which suitable for anytype of installation environment, e.g. M-Bus (EN1434), RS485 (Modbus), Pulse, LoRaWAN, Sigfox.



## Flexible Battery Life Span



B12 VI-B-IVZO has no moving parts, presents as IP65, and its body is fabricated from durable brass material. This robust design makes the B12 VI-B-IVZO maintenance-free and highly precise throughout its flexible 6 or 10 or 16 years battery life depends upon customers' needs.

## B12 VI-B-IVZO Series 04 Ultrasonic Heat Meters consist 3 main units:

Ultrasonic Flow Metering Unit

Temperature Metering Unit

Calculator Unit

### 01 Ultrasonic Flow Metering Unit

Ultrasonic flow meter measures by the transfer of ultrasound signals between transducers with the help of mirrors.

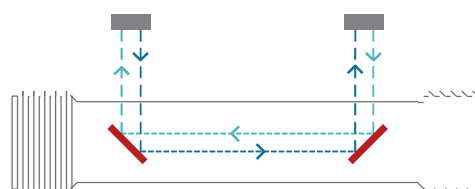

### 02 Temperature Metering Unit

PT1000 type heat sensors are used which they are calibrated, certified. If input water temperature metering probe is integrated with the meter body where flow meter is, thus the output water temperature metering probe is mounted to a suitable point on the network return water direction. Also meter could be installed in out flow position.

Default cable length is 1.5m, but 3m length is also available as per request.

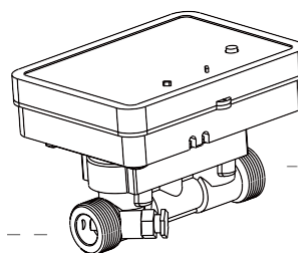

### 03 Calculator Unit

It is the unit that process energy calculation by the flow rate data received from flow rate metering unit and temperature data received from temperature metering unit. Its calibration is performed in software at factory.

Calculated energy and other information is displayed on the LCD when button is pushed. These information may be remotely read via optical port and communication unit..

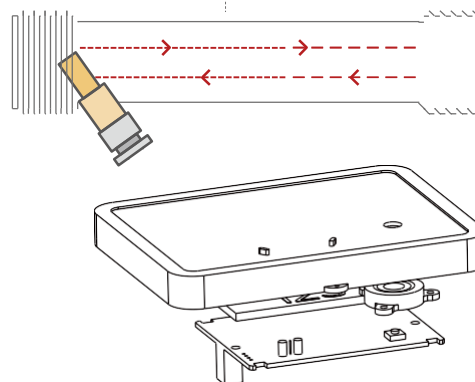

## DIMENSIONS

Model	B12 VI-B-15	B12 VI-B-20	B12 VI-B-25	B12 VI-B-32	B12 VI-B-40
Pipe Diameter	DN15	DN20	DN25	DN32	DN40
Minimum Flow Rate, $q_i$ (m <sup>3</sup> /h)	0.02	0.05	0.07	0.12	0.2
Permanent Flow Rate, $q_p$ (m <sup>3</sup> /h)	1.5	2.5	3.5	6	10
Maximum Flow Rate, (m <sup>3</sup> /h)	3	5	7	12	20
Overload Flow Rate, (m <sup>3</sup> /h)	4.5	6.5	10	18	24
Connection	G3/4'	G1'	G1' 1/4	G1' 1/2	G2'
Length (mm)	110	130	160	180	200
Width (mm)	96	105	114	120	130

## TECHNICAL SPECIFICATION

Temperature	Range: 4°C - 95°C, T: 3k - 65k
Temperature Sensor	A pair of PT1000 platinum resistor
Metrological Class	Class 2, (EN1434)
Maximum Operation Pressure	1.6Mpa
Pressure Loss	$\Delta P < 25 \text{ kPa}$ at qp
Pressure Stage	PN16
Protection Class	IP65/ IP68
Battery	6/ 10/ 16 years
Data Storage	<ul style="list-style-type: none"> <li>• 36 months history data, including accumulated heat energy and volume, etc.</li> <li>• Total heat energy, volume, running hours, etc..</li> </ul>
Operating Temperature	-30°C - 55°C
Interface & Communication	<ul style="list-style-type: none"> <li>• M-Bus</li> <li>• RS485</li> <li>• Pulse Output/ Pulse Input</li> <li>• LPWAN (LoRaWAN, Sigfox)</li> </ul>
Installation	Horizontal or Vertical
Display and Indication	<ul style="list-style-type: none"> <li>• Unit: kWh, MWh, GJ (optional)</li> <li>• LCD: 8-digit (back illumination)</li> <li>• Accumulated: 0.1kWh-9999999.9kWh.</li> </ul>
Standard Compliance	<ul style="list-style-type: none"> <li>• EN1434</li> <li>• OIML R 75</li> </ul>

B12 VI-B Ultrasonic Heat Meter Pressure Loss

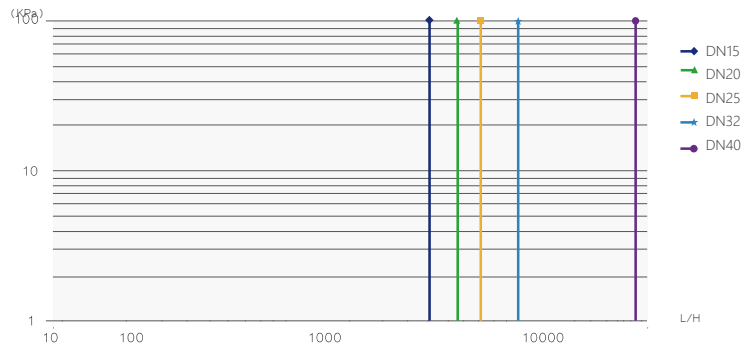
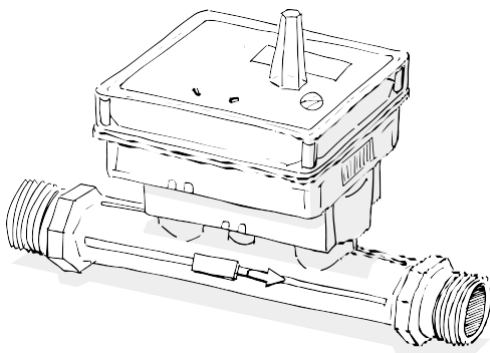

## WHY CHOOSE VICONICS-IND.....

When it comes to water flow measurement, Bove is the one of the most excellence. And we want to explain why you should trust us when we say that choosing a Bove products equals choosing reliability.

In our manufacturing plant, you will find a dedicated research and development team that gives us the ability to face your local needs and challenges head-on—regardless of size or requirements. And thanks to our in-house laboratories and highly-skilled engineers, we can develop innovative and user-friendly products faster than ever. A manufacturing capacity reaching millions of units in our plant ensuring on-time delivery, and meanwhile Bove ensures the highest level of quality and reliability through standards such as ISO 9001 and ISO 14001.....