



The high-precision bulk Ultrasonic Water Meter, developed for indoor/ outdoor Commercial, District, Industrial, and Agricultural application
Multiple Ultrasound Channel Measurement

B39 VW-M





Introduction

B39 VW-M launched by BOVE combines years' experience in metering research and development, adopting state-of-the-art technology and sophisticated production. It has been proven that B39 VW-M is reliable and absolute matured achievement in high accuracy measurement. In which B39 VW-M is designed with multiple ultrasound principle to match various demands.

In addition, the special compact design does completely assure the quality of water-proof protection. The accuracy is guaranteed even if it is installed under water in a long time. Moreover, the core engineering concept of B39 VW-M aims at cutting down the budget on overall operating costs from remote meter readings (AMR).

B39 VW-M Specs

	B39 VW-M
Material	Cast Iron
Ultrasonic Channels	Multiple Ultrasound
LCD Display	Enlarger LCD display
Bulk Size	DN50-DN900

01 No Moving Parts, high accuracy for years' long.

B39 VW-M offering none moving components in flow sensor, avoid long term abrasion of mechanical parts which may result to inaccuracy measurement and failure of meter. Such design is also resistant to impurities, therefore no-inspections and maintenance cost-free.

02 AMR Ready (wired & wireless)

B39 VW-M series support multiple communication interfaces for both wired and wireless which suitable for any type of installation environment, e.g. M-Bus (EN1434), RS485 (Modbus), Pulse, LoRaWAN, NB-IoT, Sigfox, etc.

With communication interfaces meter is easily integrated into Automatic Meter Reading (AMR), which provide reliable and scalable network to utility and bring down the meter reading cost for any application.



Long Duration Life Time

B39 VW-M has no moving parts, presents IP68 on fully water proof, and its body is fabricated from durable cast steel material. This robust design makes the B39 VW-M maintenance-free and highly precise through out its flexible 6/ 10/ 16 years battery life depends upon customers' needs.



Support Multiple Application

B39 VW-M has various range in size, B39 VW-M sized from DN50 to DN900. They are capable to be applied from commercial, district to agricultural and industrial applications.

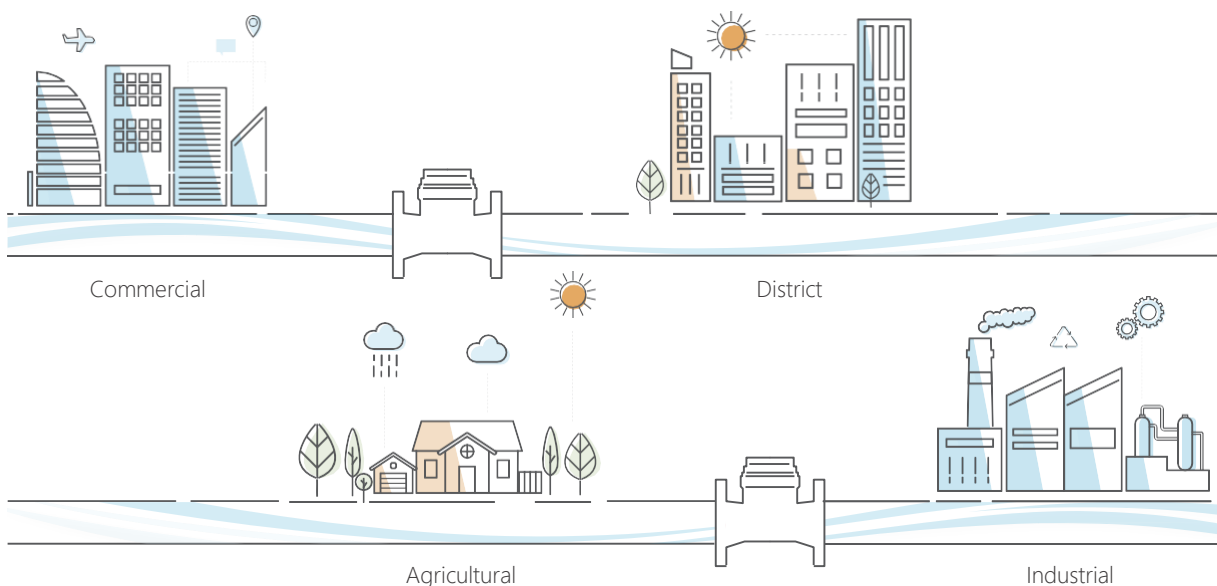

DIMENSIONS

Model	Diameter	Nominal Flow Rate	Transitional Flow Rate	Minimum Flow Rate	Flange Outer Diameter	Length	Connection Bolt
	DN (mm)	Q ₃ (m ³ /h)	Q ₂ (m ³ /h)	Q ₁ (m ³ /h) _{@R500}	mm	mm	Bolt (flange)
DN50	50	25	0.08	0.05	165	200	4×M16
DN65	65	40	0.128	0.08	185	200	4×M16
DN80	80	63	0.2016	0.126	200	225	8×M16
DN100	100	100	0.32	0.2	220	250	8×M16
DN125	125	160	0.512	0.32	250	250	8×M16
DN150	150	250	0.8	0.5	280	300	8×M20
DN200	200	400	1.28	0.8	335	345	12×M20
DN250	250	630	2.016	1.26	405	445	12×M24
DN300	300	1000	3.2	2	460	500	12×M24
DN400	400	1600	5.12	3.2	580	600	16×M27

Upto DN900, refer to BOVE for further details



TECHNICAL SPECIFICATION

Accuracy Class	Class 2
Range Ratio (Optional)	R160, R200, R250, R400, R500
Maximum Working Pressure (MPa)	1.6
Pressure Loss	$\Delta P \leq 40 \text{ kPa}$
Communication Interface (Optional)	M-Bus, RS485, LoRaWAN, NB-IoT, Sigfox, GPRS, 4-20MA, Pulse.
Medium Temperature Range	0.1°C.....50°C
Storage Temperature Range	-20°C.....55°C
Environmental Requirement	E1, M1, B
Battery Life (Optional)	6/ 10/ 16 years service life
Protection Class	IP68
Flow Field Sensitivity	U5/ D3
Flow Pipe Material	Cast Iron
Data Storage (Optional)	24/ 120 logs, daily/ weekly/ monthly.
Installation	360 degree

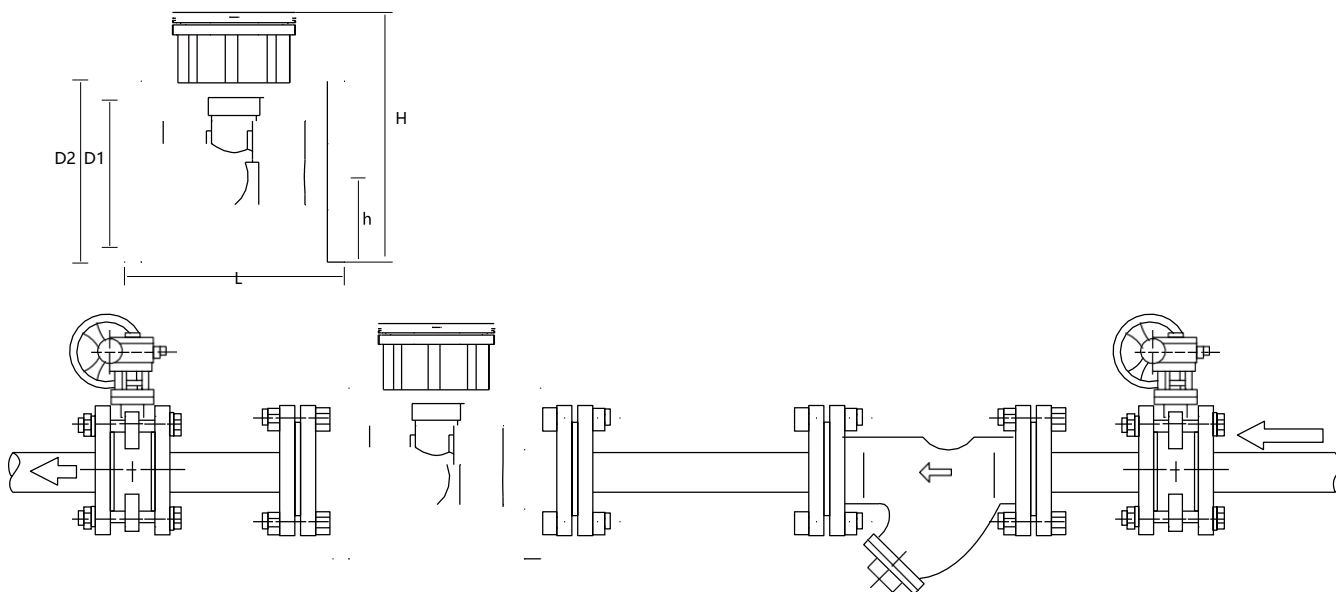

WHY CHOOSE VICONICS-IND.....

When it comes to water flow measurement, Bove is the one of the most excellence. And we want to explain why you should trust us when we say that choosing a Bove products equals choosing reliability.

In our manufacturing plant, you will find a dedicated research and development team that gives us the ability to face your local needs and challenges head-on—regardless of size or requirements. And thanks to our in-house laboratories and highly-skilled engineers, we can develop innovative and user-friendly products faster than ever. A manufacturing capacity reaching millions of units in our plant ensuring on-time delivery, and meanwhile Bove ensures the highest level of quality and reliability through standards such as ISO 9001 and ISO 14001.....