

BECO X-IVZO

Remote Reading Ultrasonic Water Meter, developed for residential application

Qi: 0.005-0.032m³/h

Supporting M-Bus, RS485, Pulse, LoRaWAN, NB-IoT, Sigfox

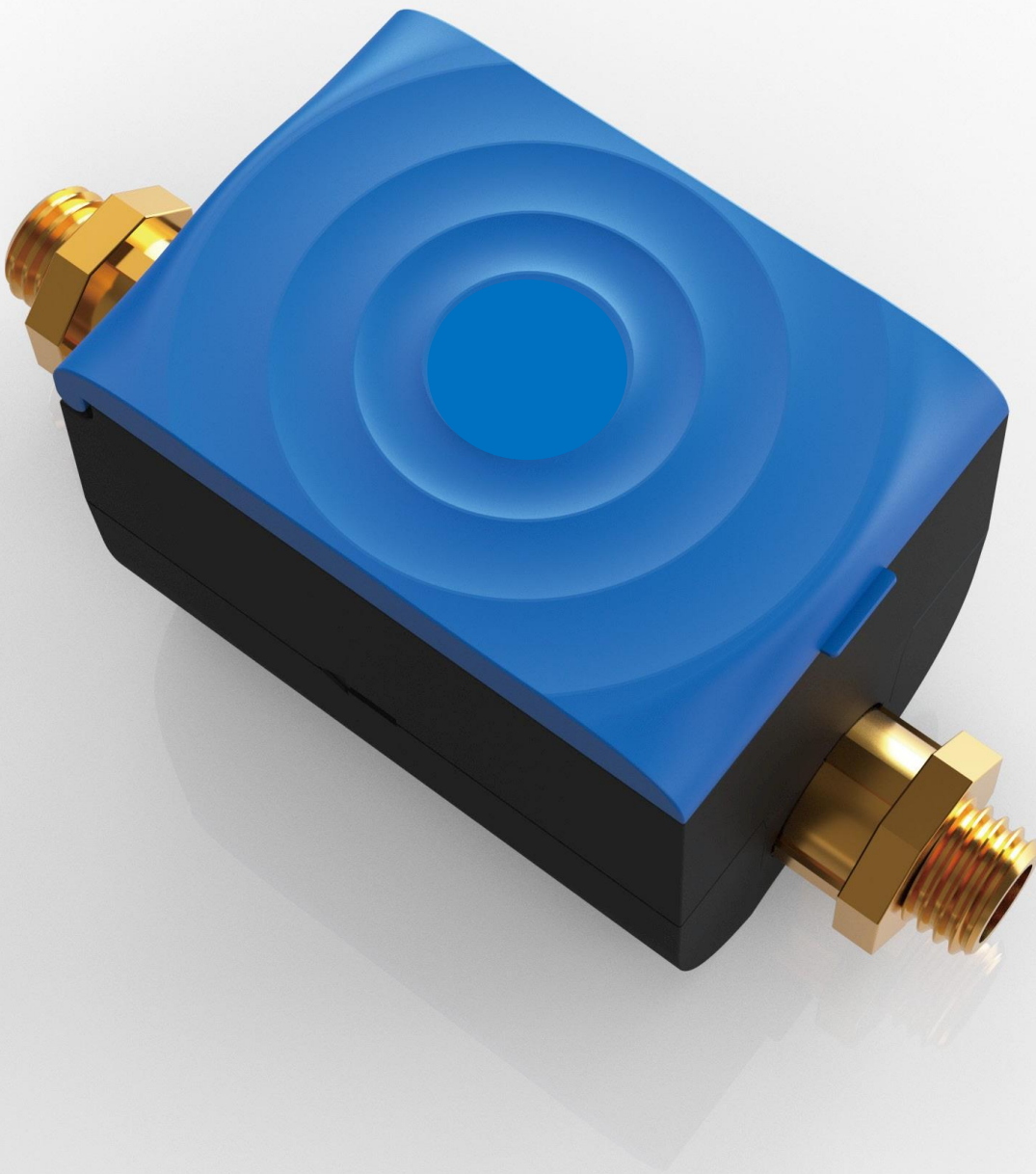

This time, a next-generation ultrasonic water meter, BECO X-IVZO is released after Bove engineers' two years dedication.

A fresh new firmware enabling an overall power consumption lowering by 18 percent. With same battery plan, BECO X-IVZO offers our customer a longer period measurement on various



Metering firmware upgrade



power consumption lowering by 18 %

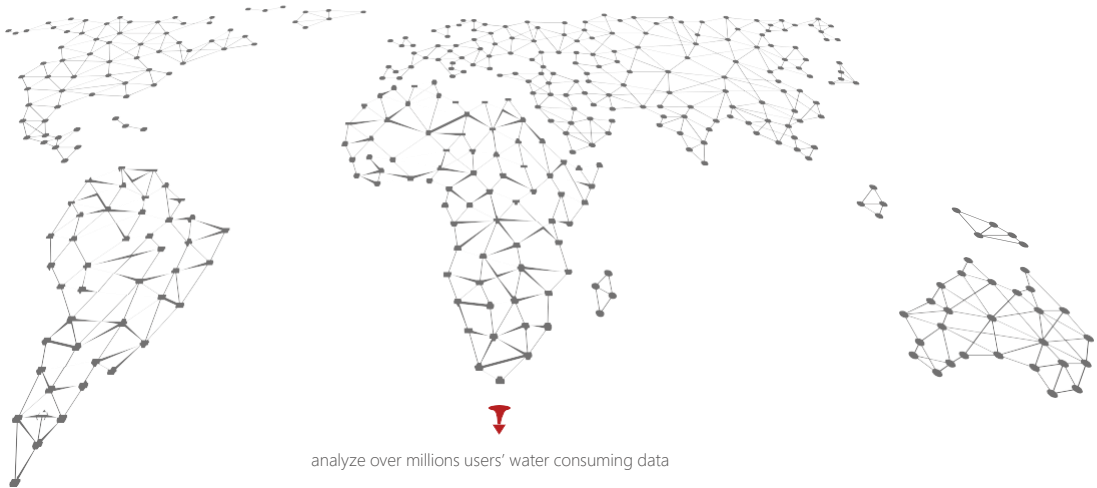

Working together with AMI System, BECO X-IVZO is able to collect and analyze over millions users' water consuming data. Bove's engineers are able to optimize the meter metrology and communication by utilizing these big data. Utilities also upgrade their water supply network with the help of these water consumption data.

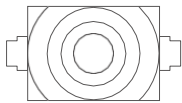

Big but hale, or Performance Monster?
BECO X-IVZO satisfy you all.

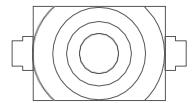

I am rigorous on meter protection.
 High temperature, high humidity, UV, all under my presiding intelligence.



High temperature



High humidity

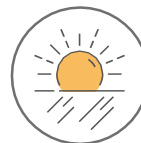

UV

'No trouble, no fear'.

We build highly coordinated metering solution for our esteemed customers. At years after re-calibration, BECO X-IVZO and BOVE's B28 VTB series calibration and testing bench working consistently to make BECO X-IVZO renew like original.

Streamline top cover coloring in ocean blue, Let every opening be a new experience.

Simple but comprehensive LCD design, making exploration of BECO X to be full of fun.

Once again upgraded photosensitive technology, make new surprise on next touch.

High precision measuring technology, when water flow across, every single drop of water is 'carved in my heart'.

Simply install on the proper position, leave the remaining work to BECO X.

Small body, big energy. Flexible lithium battery setting avoiding failure of the entire meter upon only one set of battery problem.

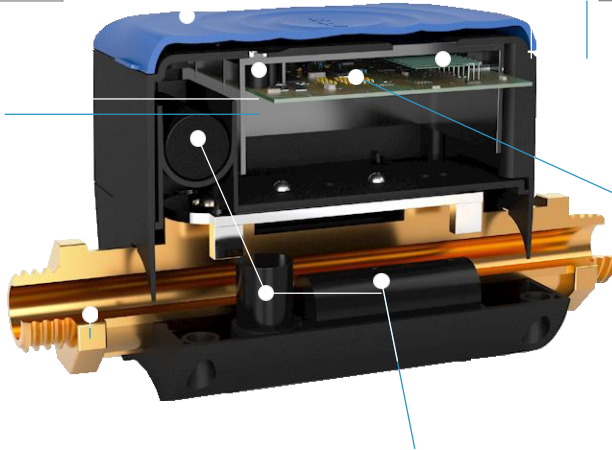

1. Flexible Battery Life Span

6-16 years 

BECO X-IVZO has no moving parts, presents as IP68, and its body is fabricated from durable brass material. This robust design makes the BECO X-IVZO maintenance-free and highly precise throughout its flexible 6/10/16 years battery life depends upon customer needs.

2. Battery Replaceable

Battery is able to get replaced in case of failure of battery sets. This action can be treated by professional engineers without any injection on electronic parts.



3. Proof of Humidity, Water and UV.

BECO X-IVZO is specially designed for extreme complex environment which has high humidity, high UV.

4. IoT Ready

BECO X-IVZO supports multiple communication interfaces for both wired and wireless which suitable for any type of installation environment, e.g. M-Bus(EN1434), RS485 (Modbus), Pulse, LoRaWAN, Sigfox, NB-IoT. Leak detection function inside meter help troubleshooting, end-service and saving the most important source of life, water.



5. Multiple Dynamic Range Options (Q3/Q1)

Application for multiple requirements. R160/ R200/ R250/ R400/ R500. Able to count every drop of water.

6. Exceptional Industry Design

Golden ratio of Length-Width-Height, splendid color assortment with Ocean Blue & Night Sky Black. Anti-dirty enclosure ensures long duration of tidy outlook same as original meter.

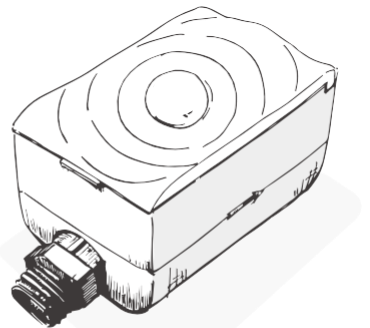

《《《 DIMENSIONS 《《《

Model	BECO X - 15	BECO X - 20	BECO X - 25	BECO X - 32	BECO X - 40
Pipe Diameter	DN15	DN20	DN25	DN32	DN40
Q ₁ (m ³ /h) _{@R500}	0.005	0.008	0.0126	0.02	0.032
Q ₂ (m ³ /h)	0.08	0.0128	0.02016	0.032	0.0512
Q ₃ (m ³ /h)	2.5	4.0	6.3	10	16
Connection	G ³ / ₄ '	G1'	G ¹ / ₄ '	G ¹ / ₂ '	G2'
Length (mm)	165	195	225	180	200
Width (mm)	81	81	81	81	81
Height (mm)	100	100	118	128	135
Temperature	<ul style="list-style-type: none"> • Medium Range: 0.1°C.....30/50/70°C (T30 / T50 / T70) • Ambient temperature: 5~55 °C • Storage temperature: -20~60 °C 				
Materials	Brass 59-1				
Metrological Class	Class 2 R160/ R200/ R250/ R400/ R500				
Maximum Operation Pressure	1.6 MPa				
Pressure Loss	ΔP≤40kPa				
Pressure Stage	PN16				
Protection Class	IP68				
Stream Field Sensitivity	U5/ D3				
Battery (Optional)	6/ 10/ 16 years service life				
Data Storage (Optional)	24/ 120 logs, daily/ weekly/ monthly.				
Environmental Requirement	E1, M1, B				
Interface & Communication (Optional)	<ul style="list-style-type: none"> • M-Bus • Pulse output • RS485 • LPWAN (LoRaWAN, NB-IOT, Sigfox) 				
Installation	360 degree				
Display and Indication	<ul style="list-style-type: none"> • Unit: L/ m³/ Gal (Optional) • LCD: 8-digit 				
Standard Compliance	<ul style="list-style-type: none"> • EN14154 • ISO4064 • OIML R49 				

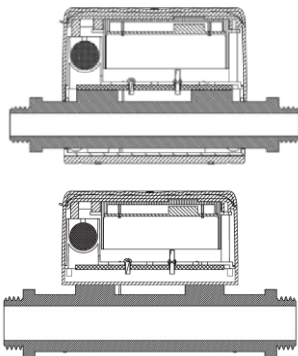

BECOX Ultrasonic Water Meter Accuracy Curve

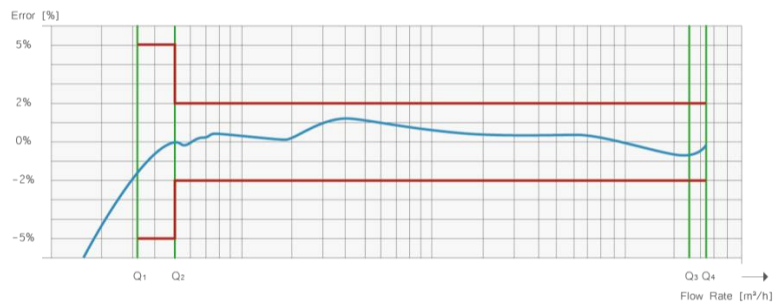

《《《 WHY CHOOSE VICONICS-IND 《《《

When it comes to water flow measurement, Bove is the one of the most excellence. And we want to explain why you should trust us when we say that choosing a Bove products equals choosing reliability.

In our manufacturing plant, you will find a dedicated research and development team that gives us the ability to face your local needs and challenges head-on—regardless of size or requirements. And thanks to our in-house laboratories and highly-skilled engineers, we can develop innovative and user-friendly products faster than ever. A manufacturing capacity reaching millions of units in our plant ensuring on-time delivery, and meanwhile Bove ensures the highest level of quality and reliability through standards such as ISO 9001 and ISO 14001.....

Add: Level 5, Building 5, No. 36, Changsheng South Road,
Jiaxing, Zhejiang, China, 314000
<https://www.techcontrolsperu.com/>

