

Installation & User Guide

B97 VPW Prepaid Ultrasonic Water Meter



Read this Guide before installing the meter

 ■ Thank you for choosing our products ■

- The contents of this manual are subject to change without prior notice as a result of continuing improvements to the meter' s performance and functions.
- Every effort has been made in the preparation of this manual to ensure the accuracy of its contents. However, should you have any questions or find any errors, please contact BOVE TECHNOLOGY.
- Copying or reproducing all or any part of the contents of this manual without the permission of BOVE TECHNOLOGY is strictly prohibited.

Bove Intelligent Technology Co., Ltd

Add: Level 5, Building 5, No. 36,
Changsheng South Road, Jiaxing,
Zhejiang, China, 314000

Tel: +86 573 83525916

Fax: +86 573 83525912

Email: bove@bovetech.com

www.bovetech.com

CONTENT

1. GENERAL INFORMATION	1
2. TECHNICAL SPECIFICATION	1
2.1 FLOW SENSOR	1
2.2 CALCULATOR	1
2.3 COMPLETER METER	2
2.4 DATA STORAGE	3
2.5 PHYSICAL DIMENSIONS	4
3. INSTALLATION	4
3.1 REQUIREMENTS FOR INSTALLATION ENVIRONMENT	4
3.2 BEFORE INSTALLATION	4
3.3 MOUNTING OF FLOW SENSOR	5
3.4 MOUNTING STEP	5
3.5 INSTALLATION OF NON-RETURN VALVE	5
3.6 AFTER THE INSTALLATION	6
4. POWER SUPPLY	6
5. INTERFACE & COMMUNICATION	6
5.1 IRDA	6
5.2 LORAWAN (DEFAULT)	6
5.3 RS485 (OPTIONAL)	7
5.4 M-BUS (OPTIONAL)	7
6. OPERATION & DISPLAY	8
6.1 OPERATIONS ON HOW TO DISPLAY	9
7. ERROR AND WARNING	14

1. General Information

Please note that the following installation conditions must be obeyed:

Pressure Requirement: MAP16.

Environmental Class: E1, M1

Installation requirement: There must be a distance of minimum 25 cm between signal cables and other installations.

Note: Seal or any safety marks on the meter must not be damaged or removed, and doing so will void the warranty and calibration of the meter.

2. Technical Specification

2.1 Flow Sensor

The flow sensor is a device used to measure the velocity of flow by using the principle of ultrasound. It can measure the average velocity along the path of an emitted beam of ultrasound by averaging the difference in measured transit time between the pulses of ultrasound propagating into and against the direction of the flow. The flow measurement is based on an acoustic wave time of flight principle. The flow meter body is equipped with 2 ultrasonic transducers facing 2 acoustic reflectors.



2.2 Calculator

The calculator (MCU) is a device that calculates the flow volume consumed based on signals from flow sensor. It's also the control, display and data store part for the meter.

2.3 Completer meter

Manufacturer			<i>Bove</i>	
Dimension				
DN (mm)	Length	Height	Width	G Threaded End Connection
<i>15</i>	<i>165</i>	<i>103</i>	<i>90</i>	<i>G 3/4'</i>
<i>20</i>	<i>195</i>	<i>100</i>	<i>100</i>	<i>G 1'</i>
Flow Measurement				
DN (mm)	Flow Rate (m ³ /h) @R400			
	Q ₃	Q ₂	Q ₁	
<i>15</i>	<i>2.5</i>	<i>0.01</i>	<i>0.00625</i>	
<i>20</i>	<i>4</i>	<i>0.016</i>	<i>0.01</i>	
Pressure Loss ΔP			$\leq 40\text{KPa}$	
MAP			<i>1.6 MPa</i>	
Water temperature range (Optional)			<i>0.1-30°C (T30) / 0.1-50°C (T50)</i>	
Q ₃ /Q ₁ (Optional)			<i>R160 / R200/ R250/ R400</i>	
Accuracy			<i>Class 2</i>	
Maximum permissible error in upper flow rates range Q ₂ ≤ Q ≤ Q ₄			$\pm 2\%$ (at Temperature ≤ 30°C) $\pm 3\%$ (at Temperature > 30°C)	
Maximum permissible error in lower flow rates range Q ₁ ≤ Q < Q ₂			$\pm 5\%$	
Scale interval (m ³)			<i>0.001</i>	
Capacity of calculator			<i>99999,999</i>	
Type of liquid			<i>Drinking Water</i>	
Installation requirements			<i>Min. 5*DN length of straight pipe before the meter, and Min. 3*DN length of straight pipe after the meter (DN is the diameter of meter).</i>	
Basic mounting orientation and other specified orientations			<i>Horizontal/ Vertical</i>	
Display & Indication				
Display unit (Options)			<i>m³ / L / Gal</i>	
Display LCD			<i>8-digit</i>	
Volume			<i>0.001m³</i>	
Time to LCD off			<i>Always on</i>	

Environmental Requirement	
Environmental Class	<i>E1, M1</i>
Ambient temperature	<i>5 ~ 55°C (Indoor and non-condensing)</i>
Storage temperature	<i>-20 ~ 60°C</i>
Protection Class (Optional)	<i>IP65/ IP68</i>
Data history (Optional)	<i>24/120 logs, daily/ weekly/ monthly.</i>
Interface & Communication	
Output signal for normal operation (Optional)	<i>Wired communication</i>
	<i>RS485/ M-Bus</i>
	<i>Wireless communication</i>
	<i>LoRaWAN</i>
Output display/signal for testing	<i>M-Bus, RS485, Infrared</i>
Power Supply	
Battery	<i>Lithium Battery</i>
Battery Life (Optional)	<i>6 Years / 10 Years / 16 Years</i>
24V DC (Optional)	<i>External supply for special version.</i>
Mechanical Specification	
Top cover	<i>ABS</i>
Bottom cover	<i>ABS</i>
Flow Body	<i>Brass 59-1</i>

2.4 Data Storage

1	<i>Accumulated flow for the current day/ week/ month.</i>
2	<i>Flow correction coefficient (Only stored when manufacturing).</i>
3	<i>Meter ID</i>
4	<i>Balance Date</i>
	<i>Note:2 to 4 are upgraded as per each command.</i>
5	<i>Accumulated flow volume</i>

2.5 Physical dimensions

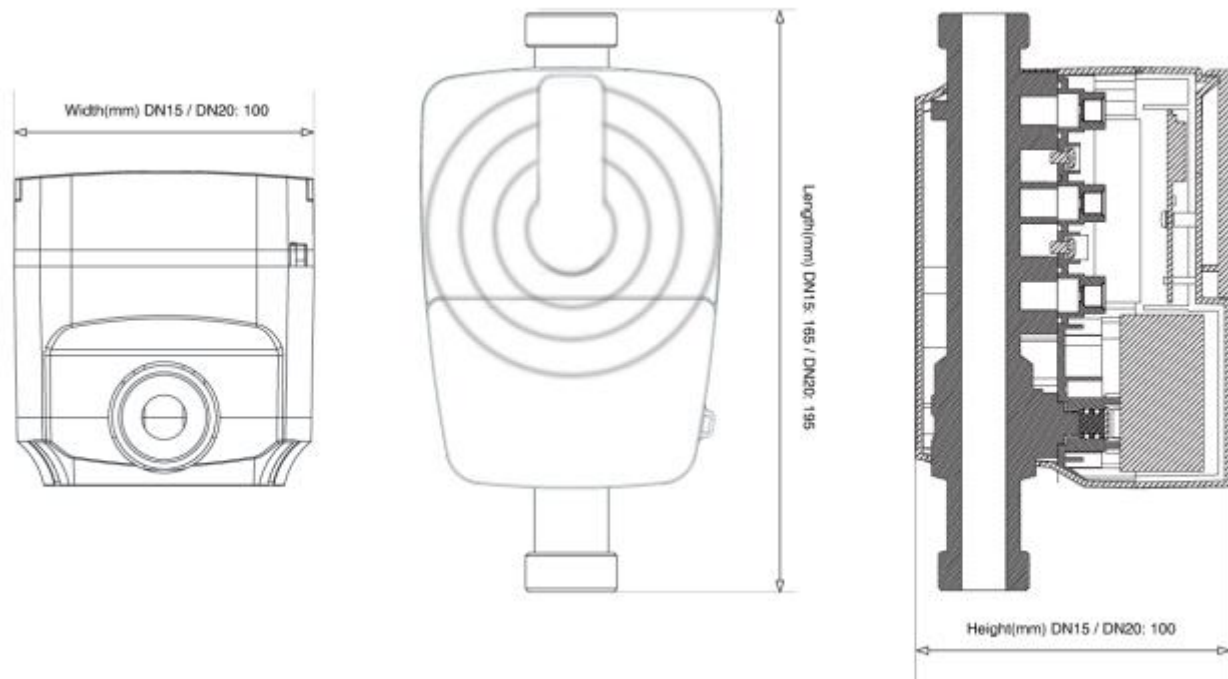

3. Installation

3.1 Requirements for installation environment

B97 VPW series ultrasonic water meter has been designed for indoor installation in non-condensing environments with ambient temperatures from 5~55°C.

The meter must not be under any mechanical stress when installed in the pipe.

The meter must be protected against pressure shocks in the pipe.

Protection class IP68 allows long-term submergence, provided that all cable unions have been correctly mounted and that the plastic cover has been properly fastened.

Make sure the meter is installed sufficiently far away from possible sources of electromagnetic interference (switches, electric motors, fluorescent lamps, etc.).

All control cables must be drawn separately and not parallel to e.g. power cables or other cables with the risk of inducing electromagnetic interference. There must be a distance of min. 25cm between signal cables and other installations.

If two or more meters are to be installed shall be in parallel, the axis-center distance between two meters shall be at least 135mm minimum.

3.2 Before Installation

Prior to installation of the flow sensor, the pipe shall be thoroughly flushed out, and any dirty, stone alike items must be removed from the pipe. Cavitation in the system must be avoided. If a risk of frost exists, empty the system and, if necessary, remove the meter. If the water is soiled, fit the strainer in the pipe before the meter.

3.3 Mounting of Flow Sensor

Consider the dimensions of the water meter, and the distance with surroundings, minimum 3 cm free space.

Straight sections of 5×DN before and 3×DN after the meter are recommended, to homogenize the temperatures of water.

The meter is to be installed so that the direction of the arrow on the meter housing corresponds to the direction of flow. Avoid the collection of air bubbles in the meter during the installation process.

The connecting pipe at the two ends must be on the same horizontal level. Install horizontally only, not tilted, inclined or overhead. Install the flow sensor into horizontal or up streaming pipelines.

Do not install at highest point of piping to avoid air inside the flow sensor. The flow sensor must not be installed in the positions where swirling flow exists (swirling flow is normally caused by bending pipe), or pulsatile flow exists (pulsatile flow is normally caused by pump, therefore the flow sensor must be installed as far as possible from pump and must not be installed on the outlet of pump) or air may build up.

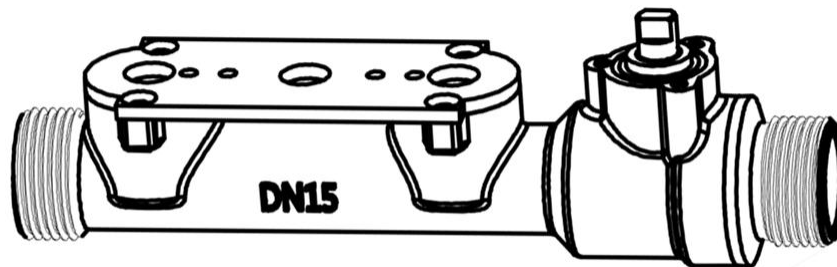

3.4 Mounting Step

Step 1: Flush the piping system thoroughly before mounting the meter.

Step 2: Sufficient distance. 10×DN straight pipe in upstream and 5×DN straight pipe in downstream. (DN: Diameter)

Step 3: The specific seal gasket and connector only supplied by Bove Technology.

Step 4: On the two sides of the meter, there should be one filter (if the water is soiled) and two shut-off valves.

Step 5: After finishing the above operations, seal the meter only if the sealing has not been done before delivery from factory.

3.5 Installation of non-return valve

The meter can be supplied with a non-return valve (if required) on request. The non-return valve must be installed on the water inlet end of meter when installing.

3.6 After the installation

The tightness must be proved by pressurizing with cold water, slowly filling the pipe on completion of the installation.

Open the shut-off valves carefully and check installation for leakage. While the piping system is operating, check whether the volume display correctly and the temperatures display corresponding with the actual temperatures (see the display information).

When the response thresholds are exceeded and the flow rate is positive, the volume is summated.

Make the segment test, in order to displays all display segments for test purposes.

The operating hours are counted from initial connection of the battery. The date is incremented daily. As a standard the meter is delivered with the local time, or destination time if required.

4. Power supply

B97 VPW Series is fitted with 2 kinds of lithium battery.

Brand	<i>EVE</i>	
Type	<i>Lithium Battery</i>	
Model No.	<i>ER26500</i>	<i>SPC1520</i>
Rated capacity	<i>8500mAh</i>	<i>45mAh</i>
Rated voltage	<i>3.6V</i>	
Max recommended continuous operating current	<i>150mA</i>	<i>500mA</i>
Max pulse current	<i>300mA</i>	<i>2000mA</i>
Reference weight	<i>52g</i>	<i>10g</i>
Max dimension	<i>26.2x50mm</i>	<i>15.1x21mm</i>
Operating temperature	<i>-60°C ~ +85°C</i>	

5. Interface & Communication

5.1 IrDA

B97 VPW Series are all equipped with an optical interface IrDA to IEC780 as a standard.

5.2 LoRaWAN (Default)

Band	<i>EU433</i>	<i>EU868</i>	<i>IN865</i>	<i>US915</i>	<i>AU915</i>	<i>AS923</i>
Class	<i>Class A</i>					
Network Access Mode	<i>OTAA or ABP</i>					

Transmitting Power	<i>12dBm</i>	<i>14dBm</i>	<i>20dBm</i>
Data transmission	<i>Each 6h as default</i>		

5.3 RS485 (Optional)

Cable: connected with four-core cable

Voltage: 5-24V.

Note: The meter reading interval should be over than 1 hour.

Version/Color	RS-485
<i>Red</i>	<i>VCC</i>
<i>Black</i>	<i>GND</i>
<i>Yellow</i>	<i>A</i>
<i>Green</i>	<i>B</i>

5.4 M-Bus (Optional)

Cable: Connected with galvanic isolation, no need to distinguish

Voltage: 50V max.

Current: M-Bus loads

Addressing: Primary or Secondary

Note: A higher frequency is not allowed and may result in meter malfunction!

Data transmission in the compatibility mode (= standard, one data frame) or in the full mode (3 data frames) is possible.

If the meter is equipped with “M-Bus”, it is delivered with a two-wire cable, which can be lengthened with a cable 2 x 0.75mm² (put a distributing box). If the meter is read out via M-bus, the allowed mean frequency of reading must not be exceeded. Any more reading is not allowed and may result in damage to the meter.

The M-Bus of the meter is supplied with a 2-wire cable with wire end ferrules.

Note: The meter reading interval should be over than 1 hour.

Version/Color	M-Bus (2-wire)
<i>Red</i>	<i>M-Bus</i>
<i>Black</i>	<i>M-Bus</i>

6. Operation & Display

B97 VPW Series is fitted with an easily readable LCD, including 8 digits, measuring units and information field.

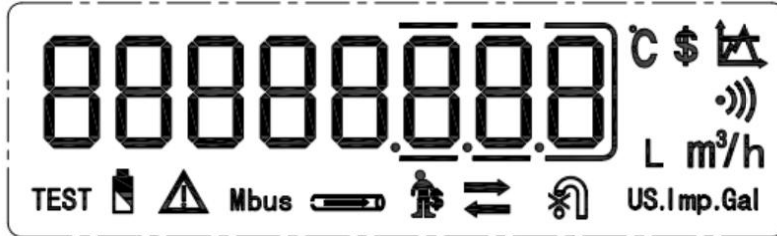











Fig. LCD Display

No.	Icon	Name	Meaning
1	TEST	<i>Calibration mode</i>	<i>Under calibration</i>
2		<i>Low battery warning</i>	<i>User is reminded to replace the battery with a new one.</i>
3		<i>Error warning</i>	<i>Warnings for error</i>
4	Mbus	<i>Communication type</i>	<i>Mbus communication</i>
5		<i>Pipe state</i>	<i>Blink means empty pipe</i>
6		<i>Credit alarm</i>	<i>Prepaid mode only</i>
7		<i>Button indication</i>	<i>Button detected once appear</i>
8		<i>Reverse flow</i>	<i>Reverse flow</i>
9		<i>Valve</i>	<i>Valve status</i>
10	US. Imp. Gal	<i>Unit</i>	<i>Gal Unit</i>
11	L m³/h	<i>Unit</i>	<i>Volume and flow rate</i>
12		<i>Wireless communication</i>	<i>Reserve</i>
13	°C	<i>Unit</i>	<i>Temperature</i>
14	\$	<i>Currency</i>	<i>Reserve</i>
15		<i>Tariff</i>	<i>Prepaid mode only</i>

6.1 Operations on how to display

Users may touching off the button (Hall) to read the meter information such as Accumulated volume, current flow rate, etc.

6.1.1 Measuring Menu List (User Loop)

Touching off the hall for more than 2 seconds and holding it on will bring up the four menus for users to select.

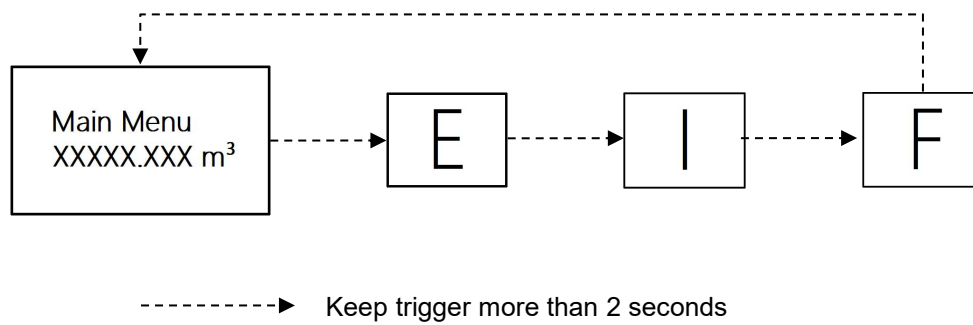

6.1.2 Main Menu

Shortly touching off the hall to display items under the Main Menu one by one in the following order to check the measurement data:

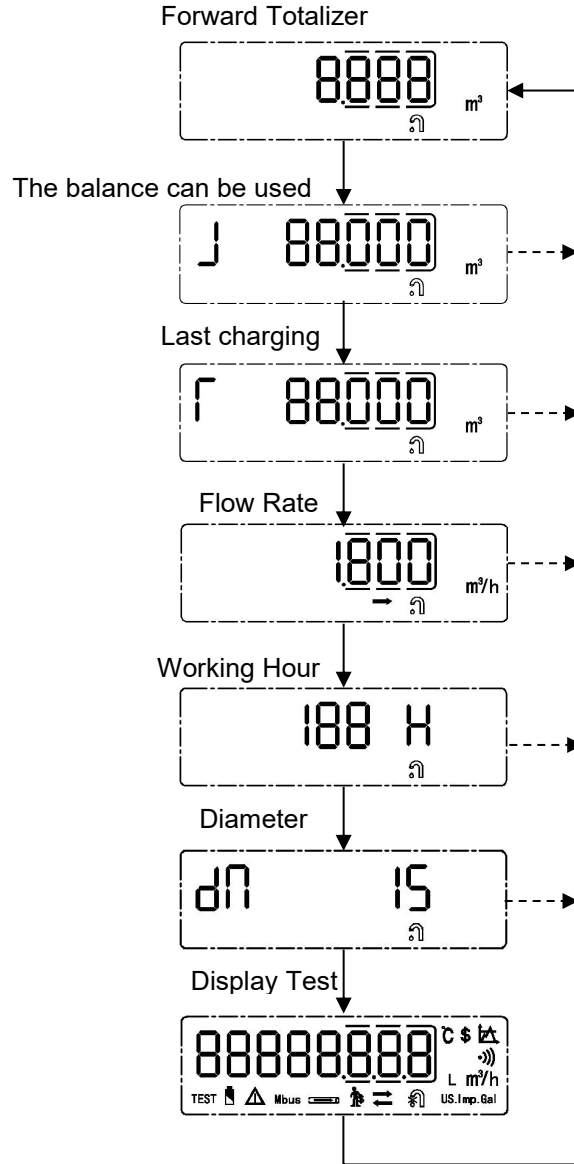

- > Short trigger less than 2 seconds
- - - - -> Keep trigger more than 2 seconds

6.1.5 Menu E

Shortly touching off the hall to display items under Menu E one by one in the following order to check the meter information:

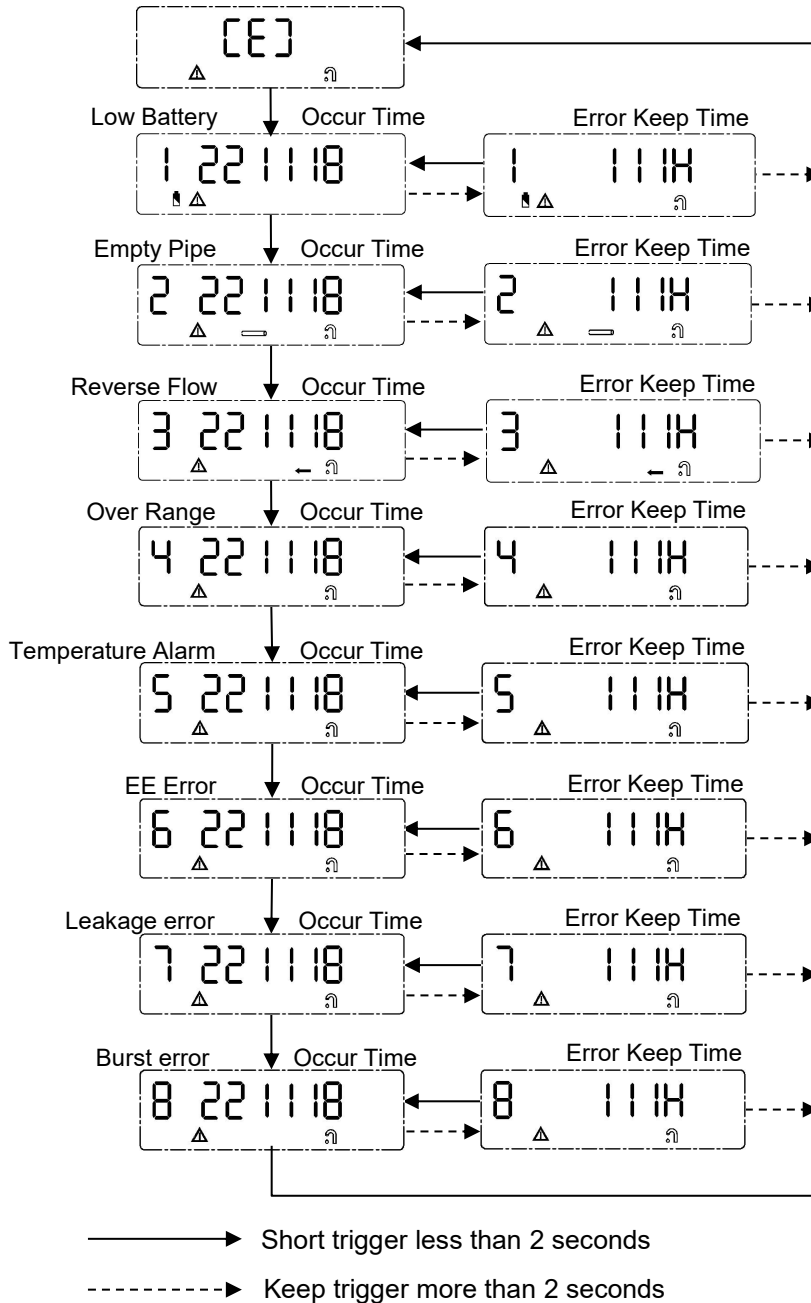

6.1.6 Menu I

This Menu shows history date records of last 24 months. Touching off the hall to select the month, then the month, monthly flow consumption will be displayed in turn.

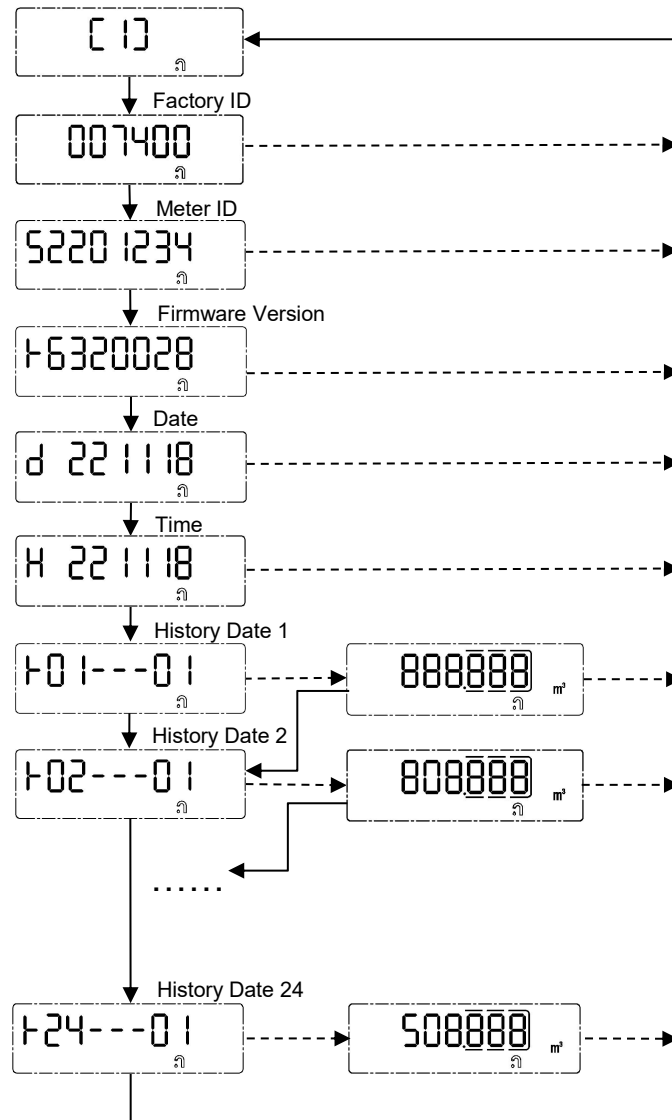

- > Short trigger less than 2 seconds
- - - - -> Keep trigger more than 2 seconds

6.1.7 Menu F

The following diagram shows Menu F (Calibration mode only). In F mode, Accumulated flow value is able to reset automatically, when flow is zero and starts to exceed the preset value then the current accumulated value is clear to zero. Also the value can be reset by long-trigger the hall (over 2 seconds). The meter exit the calibration mode if no operation for 2 hours.

Note: Preset value is pre-set to make sure zero calculation when there's no water flow in the pipe, usually the value equals to 0.1% of Q_3 .

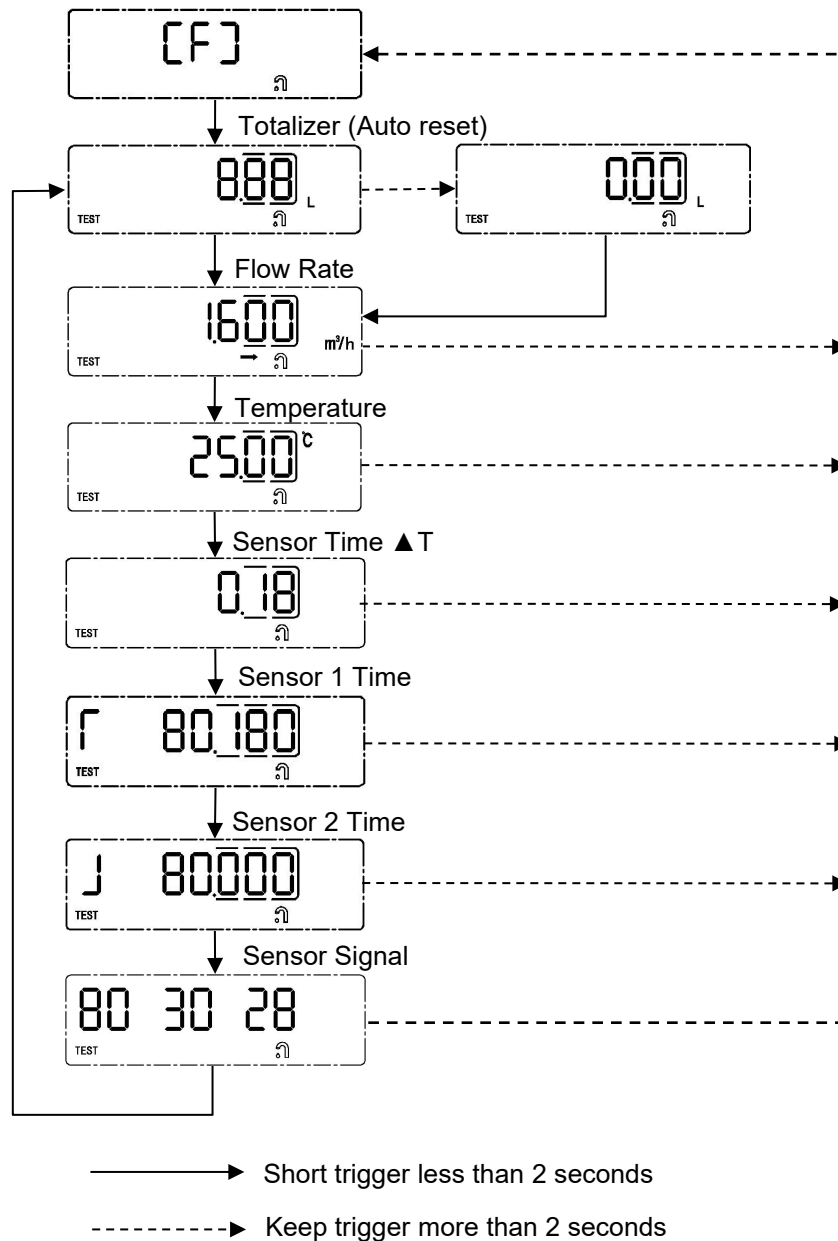

7. Error and Warning

The meter constantly performs self-diagnosis and can display various faults. Visual indication on the LCD display in the event of a warning. Permanent visual indication on the LCD.

Fault	Meaning	How to handle the error
1	<i>Low battery</i>	<i>Communication circuit to be checked</i>
2	<i>Empty Pipe</i>	<i>Fulfill the pipe with water, no air bubble.</i>
3	<i>Reverse Flow</i>	<i>Reverse the water pipe.</i>
4	<i>Over Range (High Instant flow rate)</i>	<i>Lower the instant flow rate, or change a higher Range water meter.</i>
5	<i>Water Temperature Error</i>	<i>Lower the water temperature</i>
6	<i>EE Memory Error</i>	<i>Change circuit board.</i>
7	<i>Leakage</i>	<i>Check the pipe leakage</i>
8	<i>Burst</i>	<i>Check the pipe burst</i>

Corporate Profile

Bove provides comprehensive solutions on flow metering and control to over 30 countries in the globe. We design and manufacture range of flow metering solutions and IoT (internet of things) consumer products, which includes high accuracy water meter, thermal energy meter, testing bench, smart communication softwares for residential, commercial and industrial sectors. Since 2009 Bove has always been moving on the edge of technology to deliver state of the art products and solutions to customers all around the world.

A couple of our engineers are dedicated in metering and Communication industry for over 10 years, core team are previously working in Huawei, Baidu, IBM, and CitiGroup, etc. With these talents Bove are able to provide prompt services and reliable products to our global customers.

Bove is committed to address the unique challenges that the residential and industry are facing, including increasing customer demand, water scarcity, and environment conservation. With hope, honor and our hard and quality work, we are looking to future to make Bove one of the best brands in metering industry in the world.

Our Mission

To exceed our customers expectation by providing prompt, quality and reliable technology.

Our Vision

Creating an Eco Society

Bove can accept no responsibility for possible errors in catalogues, brochures and other printed material. Bove reserves the right to alter its products without notice. This also applies to products already on order provided that such alterations can be made without subsequential changes being necessary in specifications already agreed. All trademarks in this material are property of the respective companies. Bove and the Bove logotype are trademarks of Bove Technology. All rights reserved.